

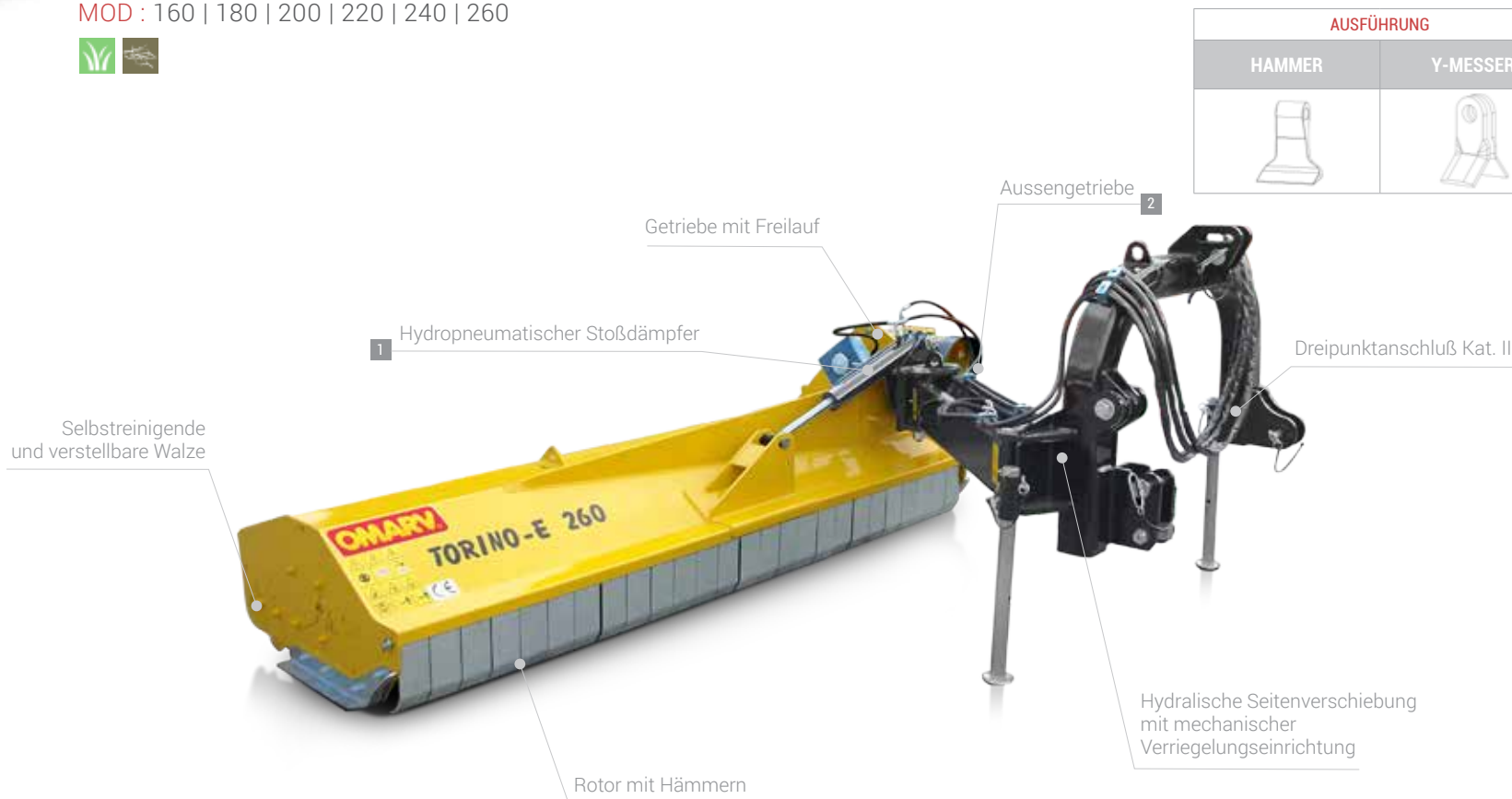

# TORINO - E

## BÖSCHUNGSMULCHER MIT AUSSENGETRIEBE - PROFESSIONAL

MOD : 160 | 180 | 200 | 220 | 240 | 260



AUSFÜHRUNG	
HAMMER	Y-MESSER
	

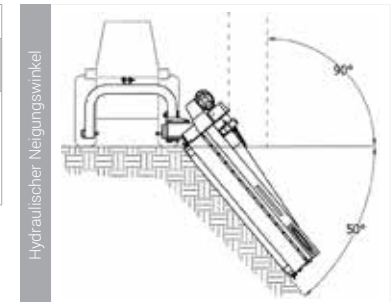







Rotor Ø mmr	180 mm	ROTOR
U / Min	1800 U/Min.	
Zapfwelle	540	

	Ø Walze	177 mm
---	---------	--------

## TECHNISCHE DATEN

TORINO-E	MODELL	HP EMPFOHLENE SCHLEPPERLEISTUNG																		
		20	40	60	80	100	120	140	160	180	200									
	160				65   100															
	180				65   100															
	200					80   120														
	220					80   120														
	240									100   180										
	260									100   180										

		TECHNISCHE MERKMALE					
	MODELL	160	180	200	220	240	260
	ARBEITSBREITE (cm)	160	180	200	220	240	260
	GESAMTBREITE (cm)	185	215	227	245	290	310
	GEWICHT (Kg)	870	900	930	960	1020	1050
	ANZAHL DER Y-MESSER	68	76	88	96	104	112
	ANZAHL DER HÄMMER	34	38	44	48	52	56
	ANZAHL DER RIEMEN SPBX	4	4	4	4	4	4



## OPTIONEN UND ZUBEHÖR

GELENKWELLE 1700 mm

DOPPEL-WEITWINKELGELENKWELLE 2200 mm (EUROCARDAN)

DOPPEL-WEITWINKELGELENKWELLE 2200 mm (B&P)

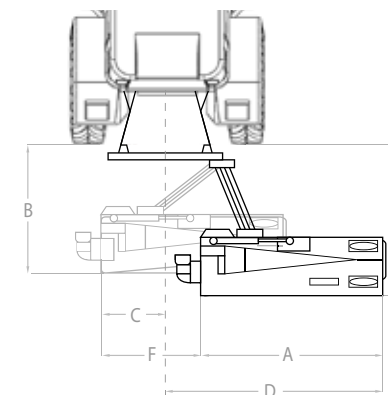

SEITENVERSCHIEBUNG (cm)						
MODELL	A	B	C	D	E	F
TORINO-E 160	160	225	30	292	220	162
TORINO-E 180	180	225	30	312	220	162
TORINO-E 200	200	225	30	332	220	162
TORINO-E 220	220	225	30	352	220	162
TORINO-E 240	240	225	30	372	220	162
TORINO-E 260	260	225	30	392	220	162